

I4213W-1 Wide band dual stage isolator, 60 Watts reverse power, 746-869 MHz

- Operational over the frequency range without retuning required
- Dual stage with 60 Watt load

Isolator, dual stage, wide band, 60 watt reverse power,

These wide bandwidth isolators allow for broad band and frequency flexible combining without having to readjust the isolators. The 700/800 MHz version is available in the following sub-bands:

Model	Frequency Range	Bandwidth
I4213W-1	746-869 MHz	123 MHz
I4213W-2	806-960 MHz	154 MHz

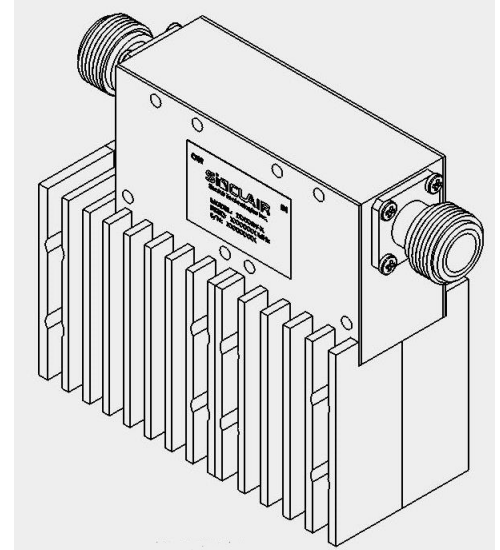

www.sinctech.com

Region	United States	Europe, Middle East and Africa	Caribbean and Latin America	Canada and rest of the world
Telephone	USA: 1 800 263 3275	International: +44 (0) 1487 84 28 19	International: +1 905 726 7676	Canada: 1 800 263 3275 International: +1 905 727 0165
E-mail	salesusa@sinctech.com	salesuk@sinctech.com	salesla@sinctech.com	salescan@sinctech.com

Electrical Specifications

Frequency Range	MHz	746 to 869
Bandwidth	MHz	123
Discription/ Characteristics		Dual Stage
Field Tunable		No
VSWR (max)		1.2:1
Insertion Loss (max)	dB	0.8
Impedance	Ω	50
Average Power Reflected (max)	W	60
Average Power Input (max)	W	125
Input Connectors		N-Female
Output Connectors		N-Female
Isolation (min)	dB	50

Mechanical Specifications

Net Weight (circulator only)	lbs (kg)	1.6 (0.73)
Number of Connectors		2
Depth	in (mm)	3.37 (86)
Height	in (mm)	3.22 (82)
Width	in (mm)	1.5 (38)
Shipping dimensions	in (mm)	9x6x3 (229x152x76)

Environmental Specifications

Temperature range	°F (°C)	-22 to +140 (-30 to +60)
-------------------	---------	--------------------------

Region	United States	Europe, Middle East and Africa	Caribbean and Latin America	Canada and rest of the world
Telephone	USA: 1 800 263 3275	International: +44 (0) 1487 84 28 19	International: +1 905 726 7676	Canada: 1 800 263 3275 International: +1 905 727 0165
E-mail	salesusa@sinctech.com	salesuk@sinctech.com	salesla@sinctech.com	salescan@sinctech.com